

## FEK-60EM

- 压模可更换设计，可压接多种类型的端子
- 采用脚踏开关控制，适用中等批量端子的压接
- 便携式和轻量型
- The crimping dies are interchangeable for crimping different terminals.
- Operated by foot switch
- Compact and light

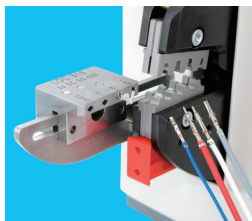

端子定位器  
Terminal positioner



压模  
Crimping die

计数器 Counter

### 工具参数

压接范围 Crimping range	0.5-16mm <sup>2</sup>
电压范围 Voltage range	AC 220-110
出力 Output	2.5T
外形尺寸 Overall dimension	140×220×320mm
重量 Weight	10Kg



FEK-60EM 备有多种样式的端子压接夹具可供选购（钳口选型见第 67 页）  
Interchangeable crimping dies for selection, see page 67

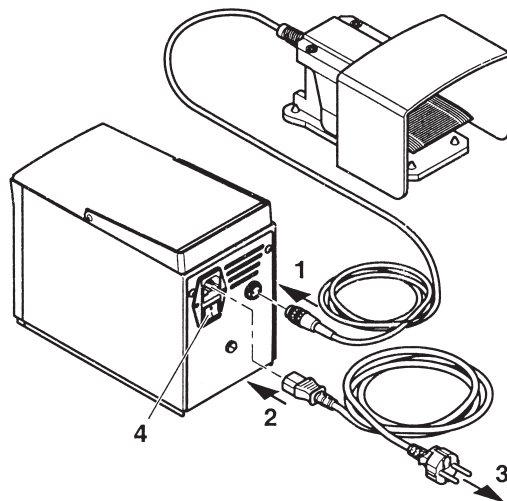

连接方法见上图  
See above diagram for the connection.

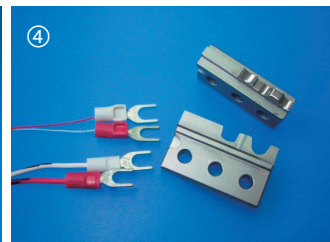
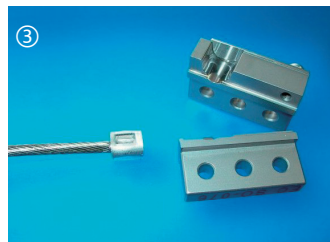
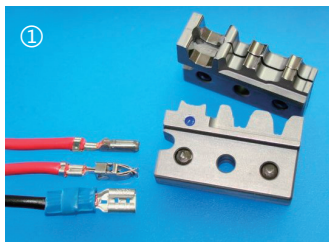

- (1) 预绝缘和插件 2 合一压接模具 Pre-plug 2-in-one insulation and crimping dies
- (2) 同轴压接模具 Coaxial crimping dies
- (3) 小铜管端头压接模具 Small brass crimping dies
- (4) 预绝缘端头压接模具 Pre-Insulated terminals crimping dies