

The PE 5300 Series is DC EMI Filters For PV Inverters(25A to 1500A)

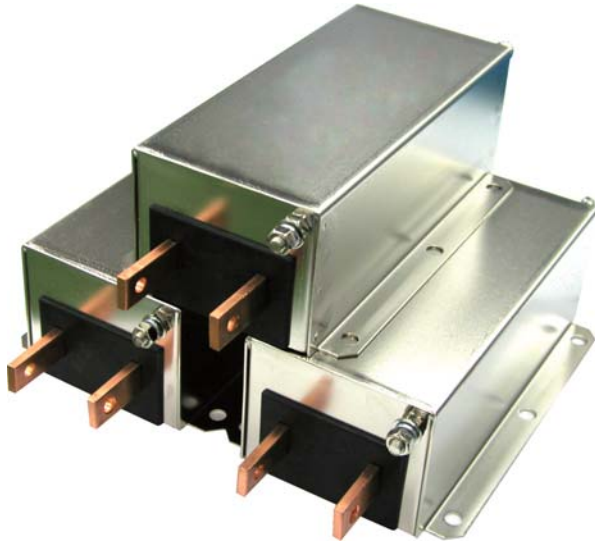

PE 5300



Description :

- Excellent interference suppression.
- Rated current from 25A to 1500A.
- High quality componets ensure the safety of filters.

Typical Applications :

- PV inverters.
- Other DC applications.

Specification :

Rated Voltag:	Max .1200 VDC
Rated Current:	25A~1500A
Temperature range:	HPF 40/085/21
Test Voltage :	
Line to Ground:	3600 VDC
Line to Line:	3000 VDC

Electrical Schematic: :

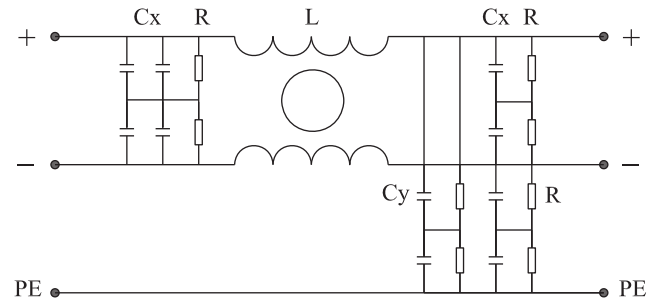

Fig 1

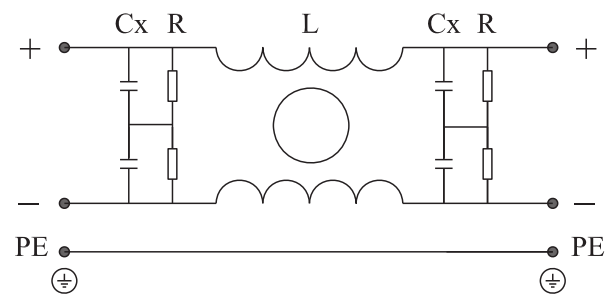
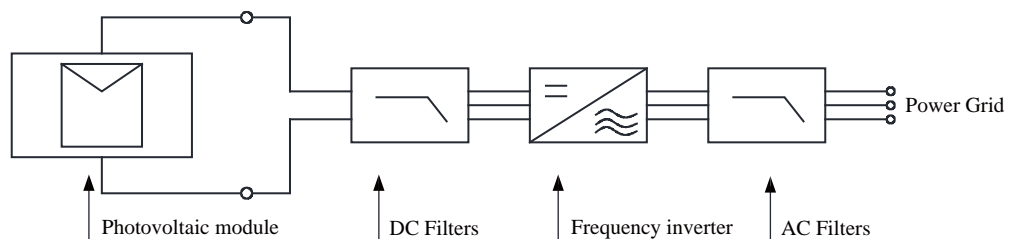



Fig 2

Connection :



Filter Selection Table :

Filter	Rated Current (A)	Rated Voltage (VDC)	Input/Output Connections		Electrical Schematic	Dimension
						
PE5300-25-60	25	Max.1200		60	1	1
PE5300-50-60	50	Max.1200		60	1	2
PE5300-75-60	75	Max.1200		60	1	2
PE5300-100-60	100	Max.1200		60	1	3
PE5300-150-60	150	Max.1200		60	1	4
PE5300-250-90	250	Max.1200	90		1	5
PE5300-400-90	400	Max.1200	90		1	6
PE5300-600-90	600	Max.1200	90		1	7
PE5300-800-90	800	Max.1200	90		1	8
PE5300-1000-90	1000	Max.1200	90		1	9
PE5300-1500-90	1500	Max.1200	90		1	10
PE5300B-25-60	25	Max.1200		60	2	1
PE5300B-50-60	50	Max.1200		60	2	2
PE5300B-75-60	75	Max.1200		60	2	2
PE5300B-100-60	100	Max.1200		60	2	3
PE5300B-150-60	150	Max.1200		60	2	4
PE5300B-250-90	250	Max.1200	90		2	5
PE5300B-400-90	400	Max.1200	90		2	6
PE5300B-600-90	600	Max.1200	90		2	7
PE5300B-800-90	800	Max.1200	90		2	8
PE5300B-1000-90	1000	Max.1200	90		2	9
PE5300B-1500-90	1500	Max.1200	90		2	10

Outline Drawing and Dimensions:

All dimensions in mm; 1 inch=25.4mm

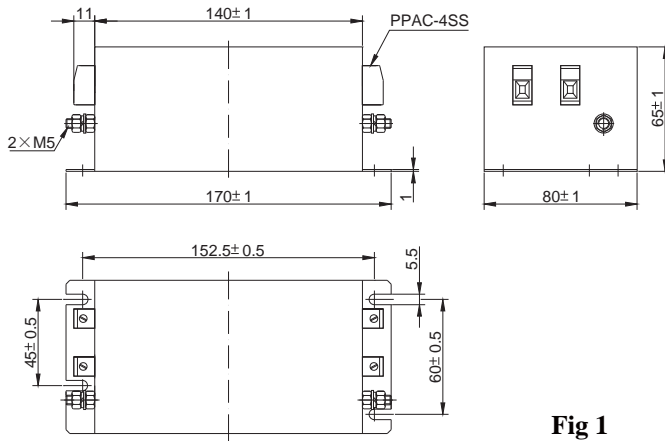

Fig 1

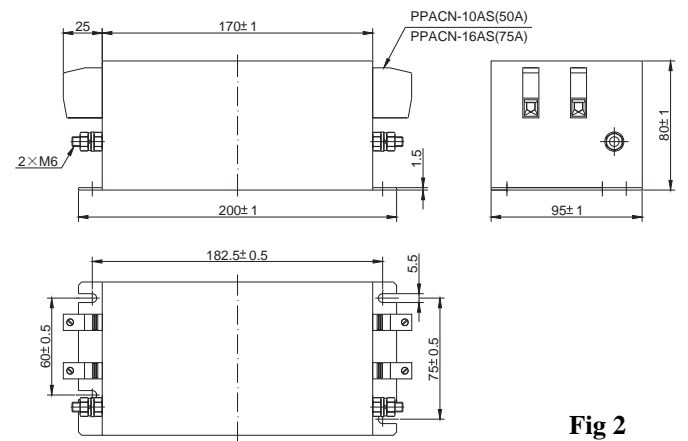

Fig 2

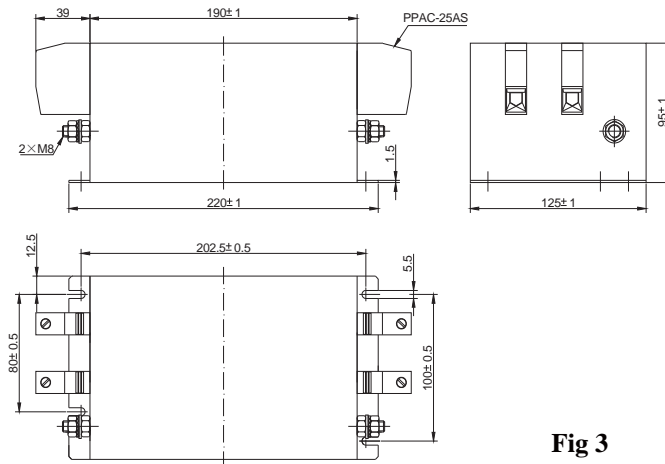

Fig 3

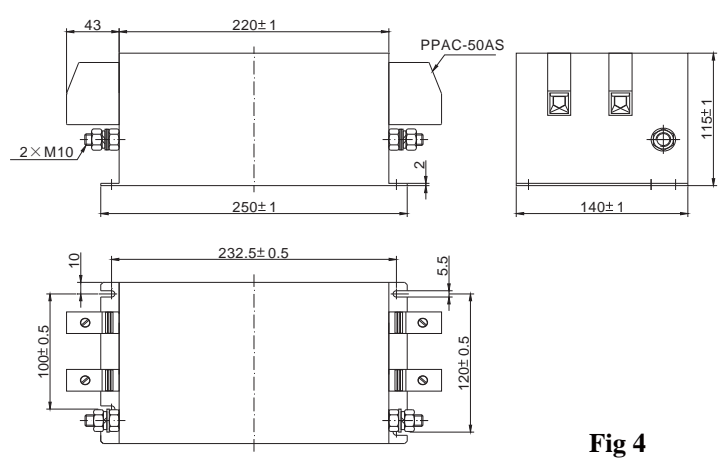

Fig 4

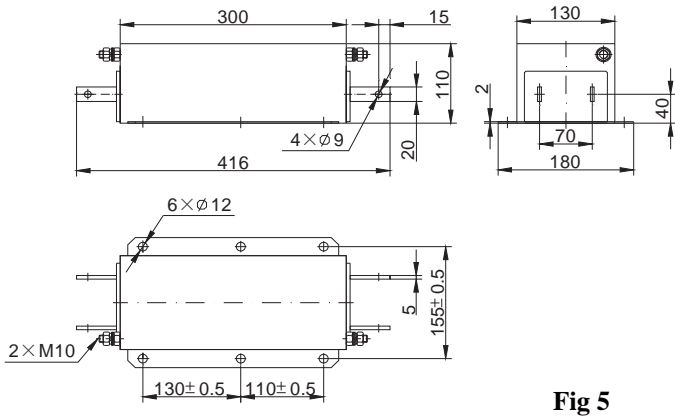

Fig 5

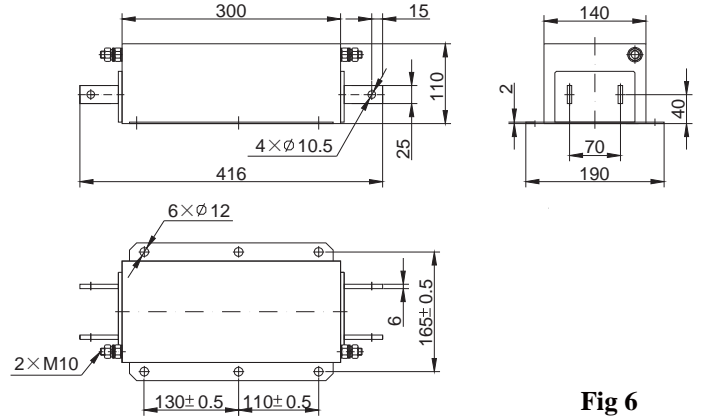

Fig 6

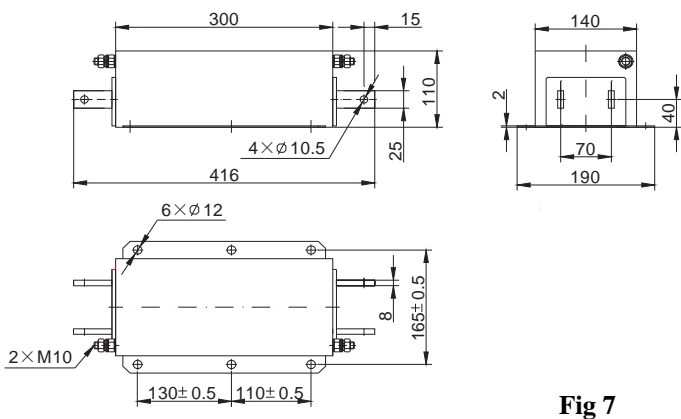

Fig 7

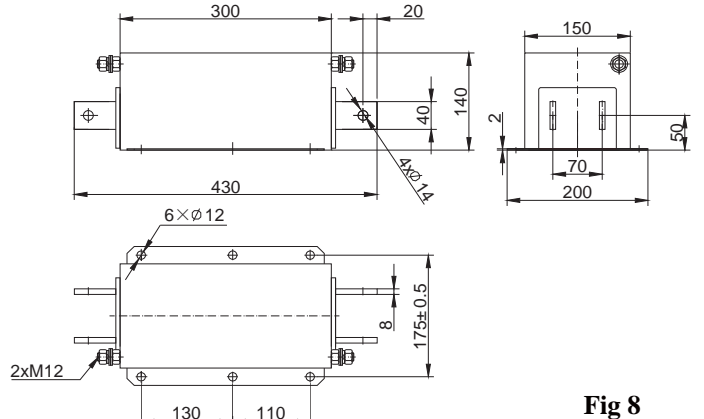

Fig 8

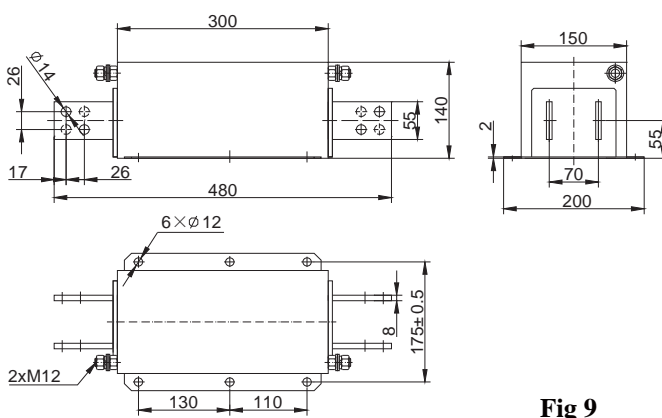

Fig 9

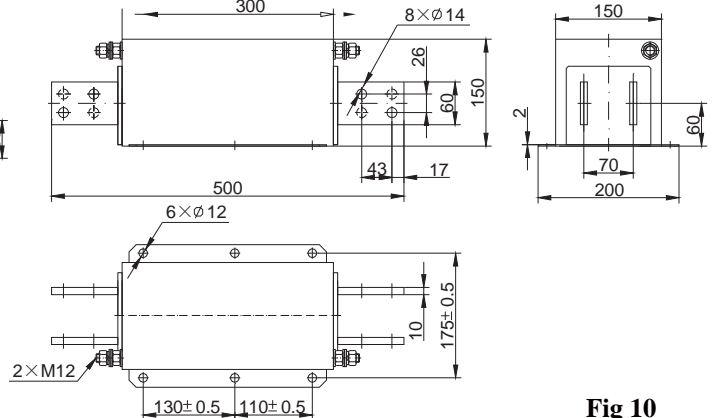
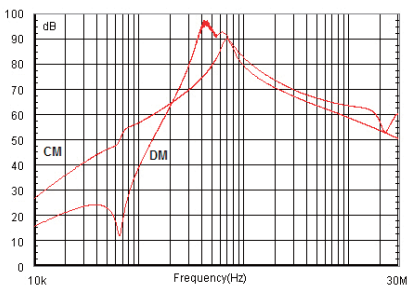

Fig 10

Insertion Loss in dB:

(Measured in 50Ω system , as IEC/CISPR NO.17)



25A

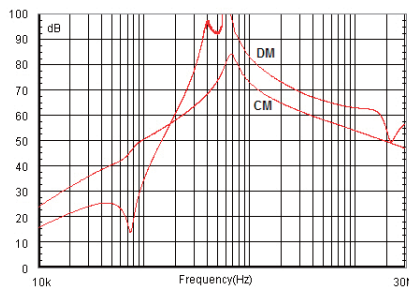

50A

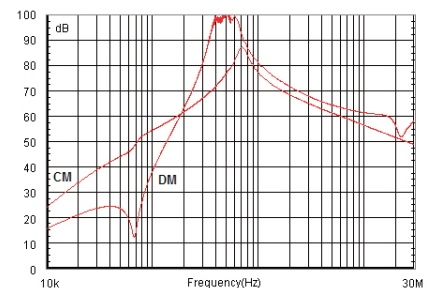

75A

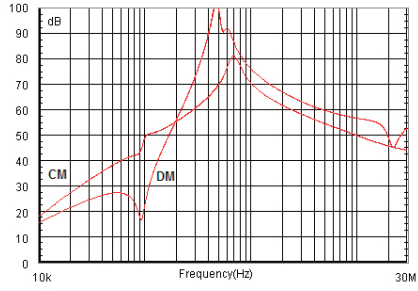

100A

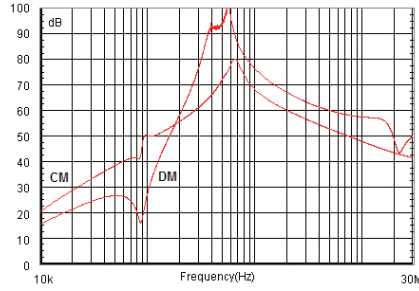

150A

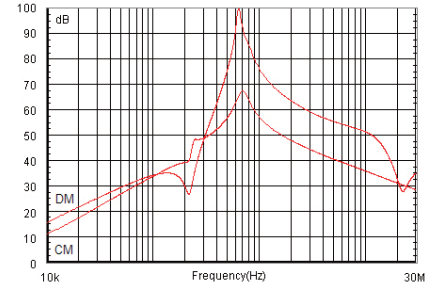

250A

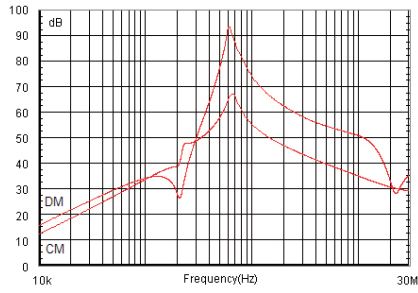

400A-600A

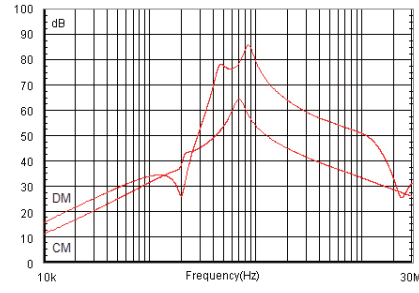

800A-1500A